

### EcoSafe double door kit

- ▶ Assembly kit for constructing an EcoSafe double door in the modular dimension system
- ▶ Use of finished protective frame as a door
- ▶ Easy subsequent installation in a protective fence
- ▶ Optional installation of a standard lock cylinder in the lock mechanism for the double door
- ▶ Required components:
  - double door assembly kit
  - two protective frames (p. 10-6)

#### Optional accessories:

- ▶ door lock (p. 8-11/8-12)
- ▶ Attachment kit for safety switch (p. 10-20)
- ▶ Conventional lock cylinder 35/35 is not included in the scope of delivery.

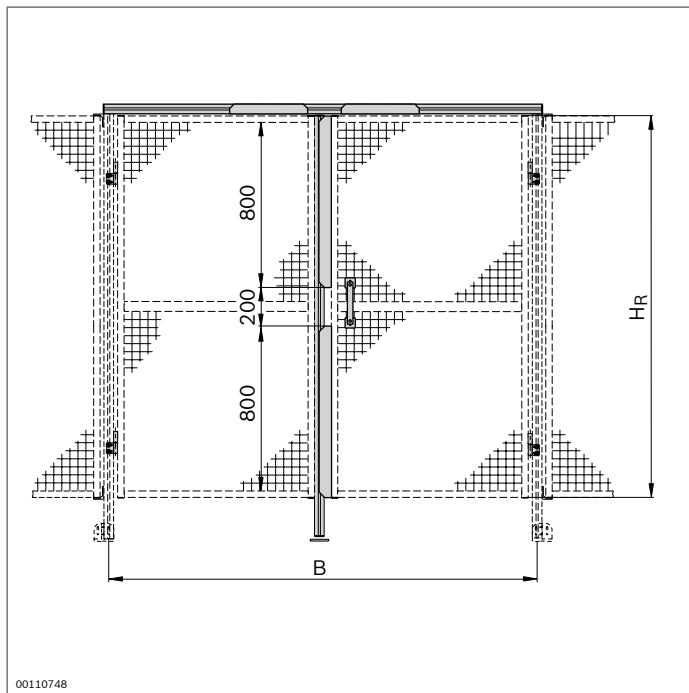

Double door assembly kit	H <sub>R</sub> (mm)	B (mm)	No.
	1800	1500	<b>3 842 525 781</b>
	1800	2000	<b>3 842 525 782</b>

Scope of delivery: lock mechanism for double door, profile for door superstructure, profile for door stop, 4 x hinge, base plate, bow-shaped handle, 2 x stop bracket for door bolts, 2 x stop bracket for door stop, fastening material

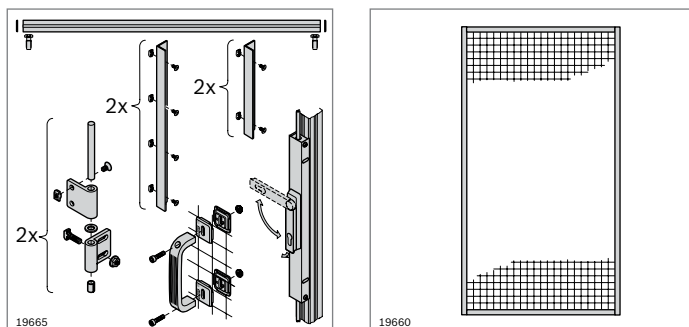

### Selection of suitable protective frames

Protective frame	H <sub>R</sub> (mm)	B (mm)	No.
Protective frame	1800	750	<b>3 842 554 283</b>
Protective frame, in horizontal sections	1800	1000	<b>3 842 554 281</b>

Material: aluminum, anodized; woven wire grille and fastening material: steel; galvanized

Condition on delivery: fully assembled