

00109652

EcoSafe sliding door without superstructure

- ▶ Assembly kit for constructing an EcoSafe sliding door without superstructure in the modular dimension system
- ▶ Use of finished protective frame as a door
- ▶ Rollers with ball bearings for smooth running
- ▶ For doors that open to the left or right
- ▶ Required components:
 - assembly kit for sliding door without superstructure
 - protective frame (p. 10-6)
- ▶ Also available with leg sets with 45x90L profiles for more stability

Optional accessories:
door lock (p. 8-11/8-13)

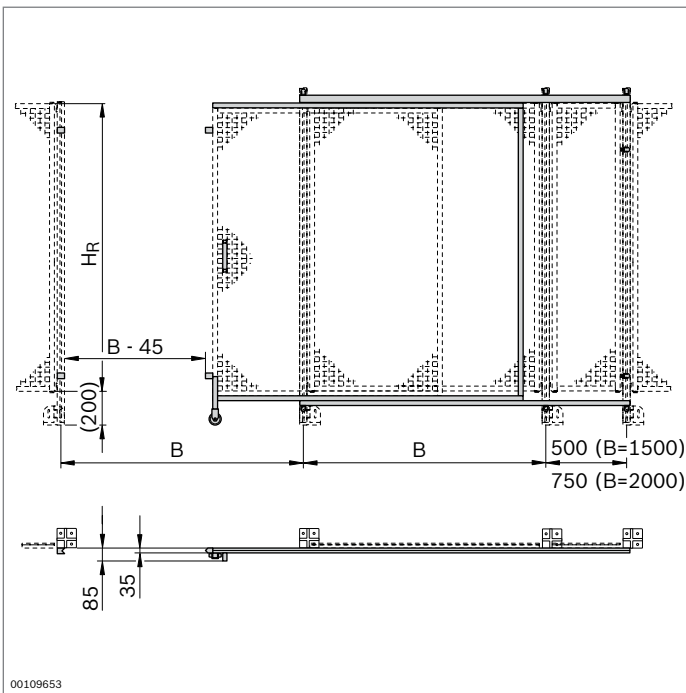

00109653

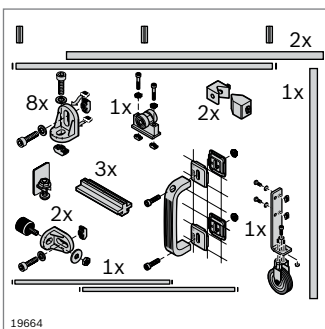

19664

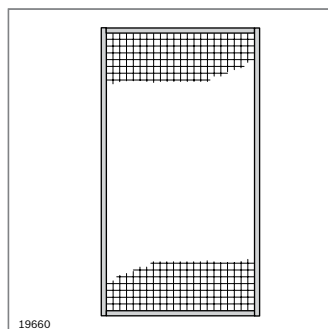

19660

Assembly kit for sliding door without superstructure	H _R (mm)	B (mm)	No.
	1800	1500	3 842 524 165
	1800	2000	3 842 524 166

Scope of delivery: 2 x bumper, 3 x slider, trolley, profile for door superstructure, 8 x mounting bracket, 2 x stop kit, 2 x profile for sliding door, incl. fastening material

Selection of suitable protective frames

Protective frame	H _R (mm)	B (mm)	No.
Protective frame	1800	1500	3 842 554 285
Protective fence, vertical sections	1800	2000	3 842 554 280

Material: aluminum, anodized; woven wire grille and fastening material: steel; galvanized

Scope of delivery: fully assembled