

Suspension bracket Safety Strip safety kit



Suspension bracket

- ▶ For mounting the EcoSafe protective frame on the support at various angles
- ▶ Suspension bracket with centering lugs as anti-torsion element

Safety Strip safety kit

- ▶ Safe and inexpensive
- ▶ Easy assembly; can be retrofitted
- ▶ Patented
- ▶ Meets the requirements of Machinery Directive 2006/42/EC Screw remains connected to the suspension bracket after loosening

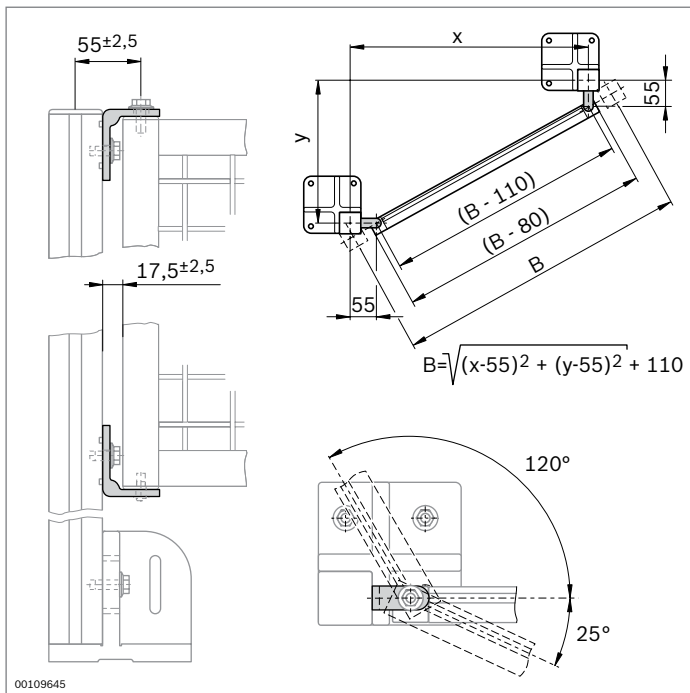

Suspension bracket	No.	FS
Set	3 842 522 481	4xFS1, 2xFS2, 2xFS3

Material: diecast zinc

Fastening material: steel; galvanized

Scope of delivery: In a set with four brackets, incl. fastening material (FS)

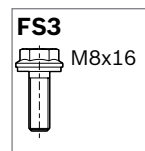
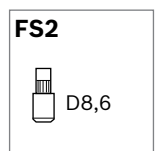
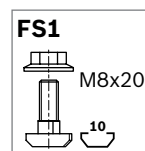
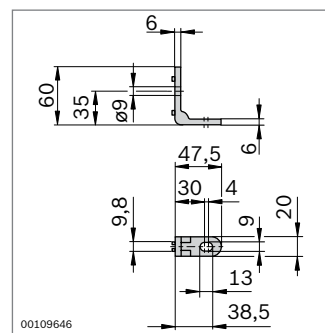

Safety strip safety kit	No.	FS
	10	3 842 542 146 FS1

Material: PP granulate

Scope of delivery: incl. fastening material (FS)

