

### Cover cap Cover cap with hole

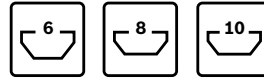

- ▶ To prevent injuries at open profile ends
- ▶ Attractive design
- ▶ Cover cap with hole for use with leveling feet and rollers
- ▶ Cap material: PA or PP

Order information for the caps can be found together with the profiles

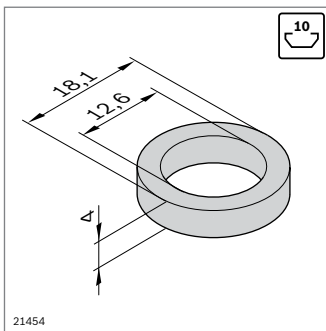

### Bearing ring

- ▶ For cover caps with hole in the sizes 40x40, 45x45, 50x50 and 60x60
- ▶ For M12 threads
- ▶ To protect the caps when tightening accessories

Bearing ring	No.
	100 3 842 555 653

Material: diecast zinc

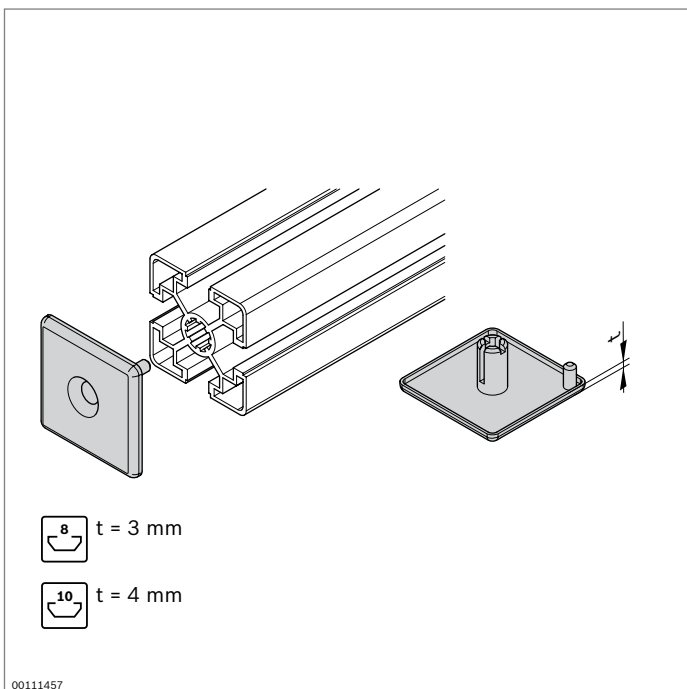

### Diecast zinc cover cap

- ▶ Shock-resistant
- ▶ Resistant to aggressive media
- ▶ Fastened with countersunk screw; profile finishing not required

Cover cap	L1xL2	ESD No.	FS
30x30-ZN	30x30	3 842 518 204	FS1
40x40-ZN	40x40	3 842 541 807	FS2
45x45-ZN	45x45	3 842 518 205	FS2

Material: diecast zinc

