

Accessory upright

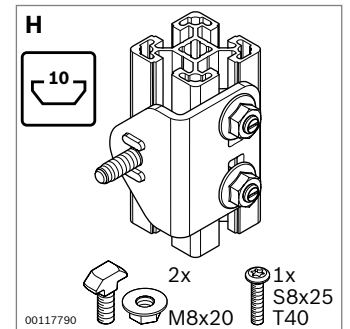
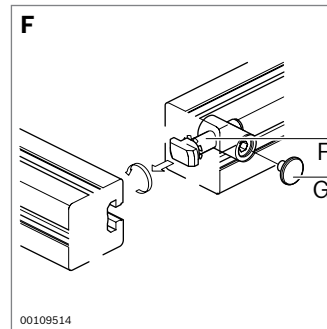
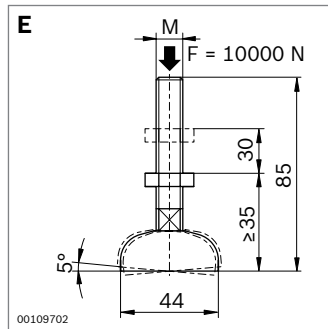
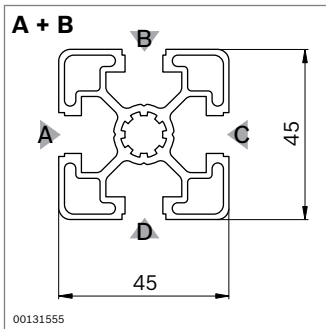
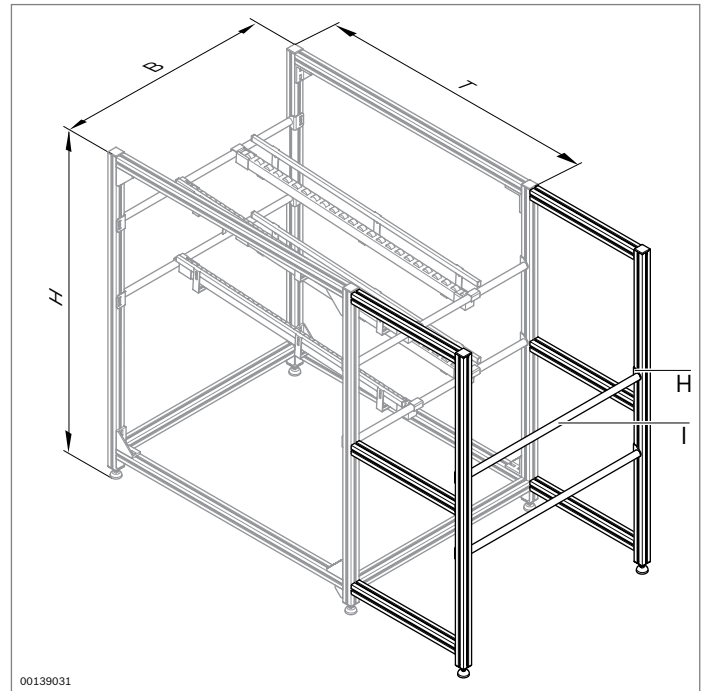
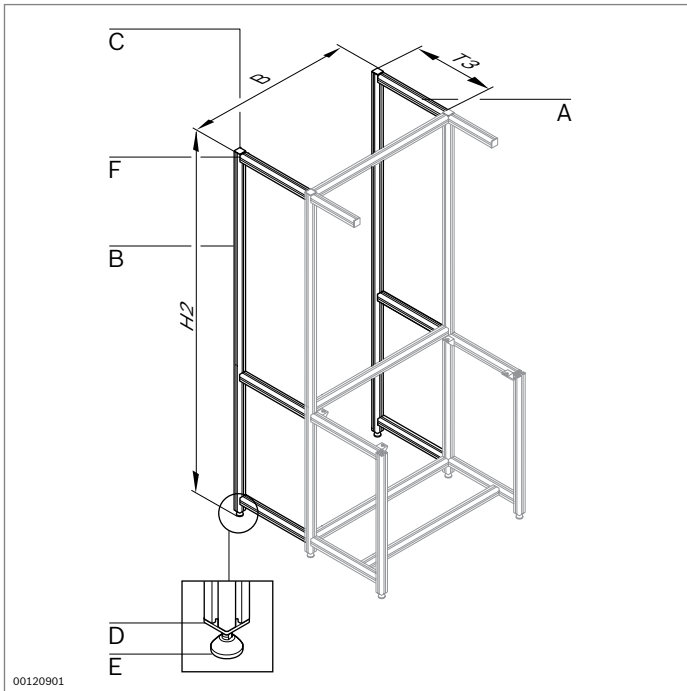

		L (mm)			ESD No.
A	45x45L strut profile, DB17 profile machining (through hole d = 17) on both profile ends; material: aluminum; anodized	50 ... 6000	1		3 842 993 737/L/ B=DB17/DB17
B	45x45L strut profile, M12 profile machining (thread in core) on one profile end; material: aluminum; anodized	50 ... 6000	1		3 842 993 737/L/ Z=M12/-
A, B	45x45L strut profile; material: aluminum; anodized	6070	20		3 842 553 611
C	45x45L cap; material: PP; black			20	3 842 548 753
	45x45L cap; material: PP, signal gray			100	3 842 548 752
D	45x45L cap with hole; material: PP; black			20	3 842 548 797
	45x45L cap with hole; material: PP, signal gray			20	3 842 548 796
E	D44 leveling foot; material: steel; galvanized			20	3 842 352 061
F	D17 quick connector for 10 mm slot (0°)			10	3 842 535 458
G	Quick connector cap; material: PA			100	3 842 538 564
H	Holding bracket with connection kit; material: steel; galvanized			20	3 842 536 002
I	D28 round tube; material: aluminum; anodized (see Figure "C" on page 180)	30 ... 6000	1		3 842 993 317/L
		6070	20		3 842 535 118